

HDPE

PIPING SYSTEMS, SEGMENTED FITTINGS, MACHINES & FABRICATION

Elbow / Bend 30°

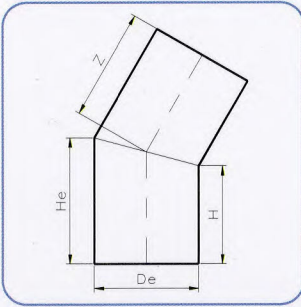

Finished Dimensions			
De	H	He	Z
630	350	518	434
710	400	590	495
800	400	614	507
900	400	641	520
1000	400	668	534
1200	480	720	640



Execution: segmented through butt welding

Elbow / Bend 45°

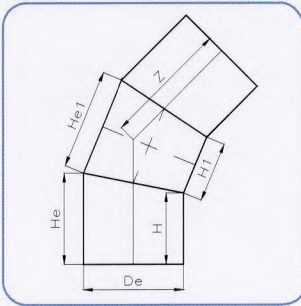

Finished Dimensions					
De	H	He	He1	H1	Z
630	350	475	710	460	729
710	400	541	752	470	801
800	400	559	788	470	820
900	400	579	838	480	846
1000	400	599	877	480	866
1200	740	960	1069	980	1250



Execution: segmented through butt welding

Elbow / Bend 60°

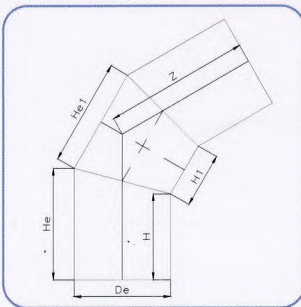

Finished Dimensions					
De	H	He	He1	H1	Z
630	350	518	797	460	797
710	400	590	850	470	876
800	400	614	898	470	902
900	400	641	962	480	937
1000	400	668	1016	480	965
1200	480	802	1219	576	1156



Execution: segmented through butt welding

Segmented bend 90°

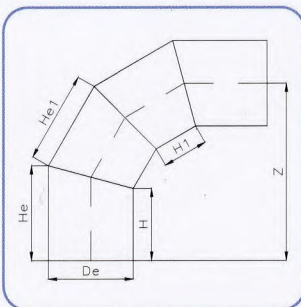

Finished Dimensions					
De	H	He	He1	H1	Z
630	350	518	797	460	1293
710	400	590	850	470	1397
800	400	614	898	470	1442
900	400	641	962	480	1505
1000	400	668	1015	480	1555
1200	480	700	1069	576	1640



Execution: segmented through butt welding

Segmented tee 45°

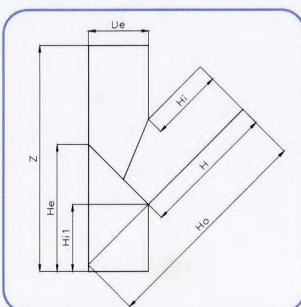

Finished Dimensions				
De	H	Hi	Hi1	Z
630	1200	569	350	1811

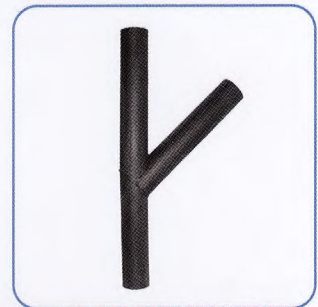

Execution: segmented through butt welding

Croce

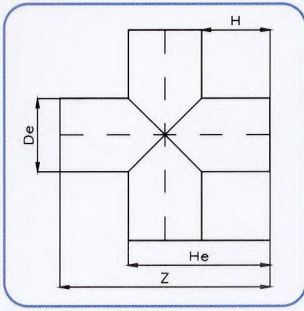

Finished Dimensions			
De	H	He	Z
630	350	980	1330

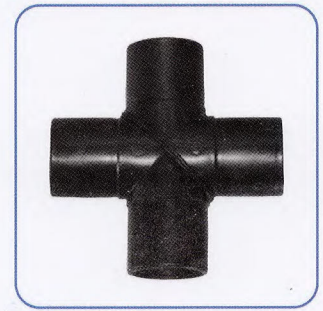

Execution: segmented through butt welding

Segmented tee 90°

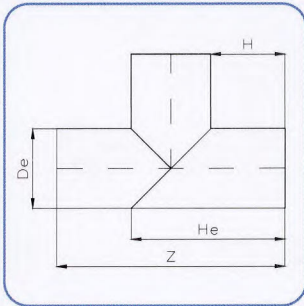

Finished Dimensions			
De	H	He	Z
630	350	980	1330
710	400	1110	1510
800	400	1200	1600
900	400	1300	1700
1000	400	1400	1800
1200	480	1680	2180

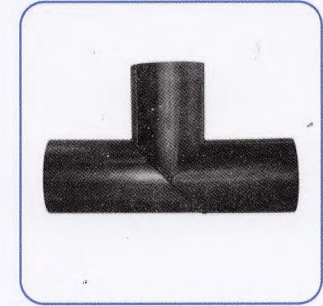

Execution: segmented through butt welding

Segmented reduced tee 90°

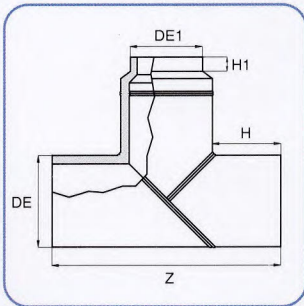

Finished Dimensions			
De	H	He	Z
630	350	980	1330
710	400	1110	1510
800	400	1200	1600
900	400	1300	1700
1000	400	1400	1800
1200	480	1680	2180



Execution: segmented through butt welding

Reducing Tee 90°

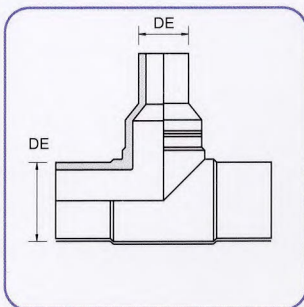

Finished Dimensions					
DE (mm)	DE1 (mm)	DE (mm)	DE (mm)	DE1 (mm)	DE (mm)
710	63	710	800	250	800
710	75	710	800	280	800
710	90	710	800	315	800
710	110	710	800	355	800
710	125	710	800	400	800
710	140	710	800	450	800
710	160	710	800	500	800
710	180	710	800	560	800
710	200	710	800	630	800
710	225	710	800	710	800
710	250	710	900	500	900
710	280	710	900	630	900
710	315	710	900	710	900
710	355	710	900	800	900
710	400	710	1000	500	1000
710	450	710	1000	630	1000
710	500	710	1000	710	1000
710	560	710	1000	800	1000
710	630	710	1000	900	1000
800	90	800	1200	400	1200
800	110	800	1200	450	1200
800	125	800	1200	500	1200
800	140	800	1200	630	1200
800	160	800	1200	710	1200
800	180	800	1200	800	1200
800	200	800	1200	900	1200
800	225	800	1200	1000	1200



Execution: segmented through butt welding

